

SWW EXTRA WIDE SERIES NON SELF-ALIGNING TYPE

These extra wide ball bushings are produced from a solid steel outer cylinder. The ball bushings incorporate either a patented all steel hardened seamless ball retainer or an industrial strength resin retainer for quiet operation.

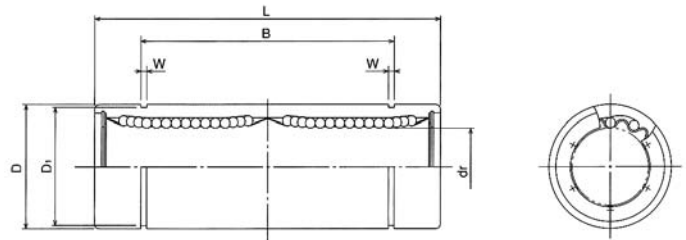
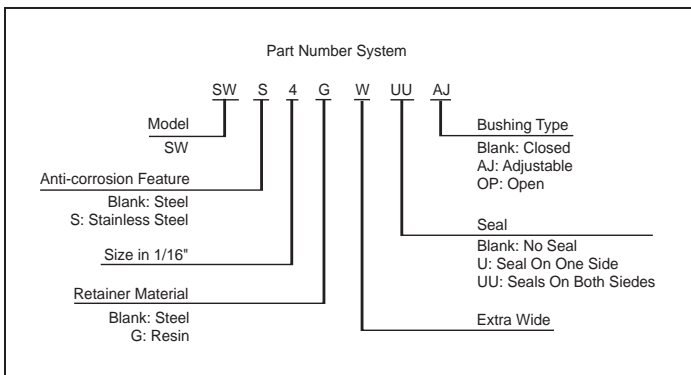
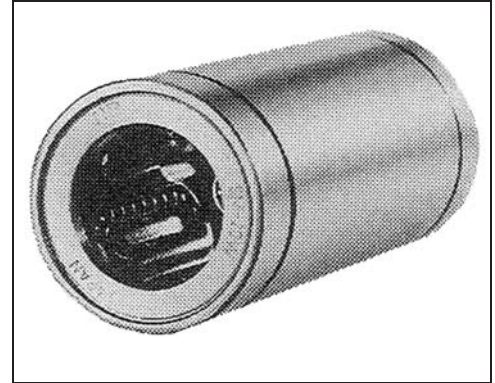

Unit: inch

Part No.	Size	Load Rating		Dimensions and Tolerances									
		Dynamic C (lbs.)	Static Co (lbs.)	dr	Tol	D	Tol	L	Tol	B	Tol	W	D1
SW4..W	1/4	73	119	0.2500	0 -0.00040	0.5000	0 -0.00050	1.3750	0 -0.012	1.0220	0 -0.012	0.0390	0.4687
SW6..W	3/8	79	142	0.3750	0 -0.00040	0.6250	0 -0.00065	1.5938	0 -0.012	1.2716	0 -0.012	0.0390	0.5880
SW8..W	1/2	183	353	0.5000	0 -0.00040	0.8750	0 -0.00065	2.3750	0 -0.012	1.9250	0 -0.012	0.0459	0.8209
SW10..W	5/8	277	529	0.6250	0 -0.00040	1.1250	0 -0.00065	2.8125	0 -0.012	2.2079	0 -0.012	0.0559	1.0590
SW12..W	3/4	308	617	0.7500	0 -0.00050	1.2500	0 -0.00075	3.0937	0 -0.012	2.3314	0 -0.012	0.0559	1.1760
SW16..W	1	353	707	1.0000	0 -0.00050	1.5625	0 -0.00075	4.2813	0 -0.016	3.5094	0 -0.016	0.0679	1.4687
SW20..W	1-1/4	563	1235	1.2500	0 -0.00006	2.0000	0 -0.00090	5.0000	0 -0.016	4.0094	0 -0.016	0.0679	1.8859
SW24..W	1-1/2	772	1809	1.5000	0 -0.00006	2.3750	0 -0.00090	5.6875	0 -0.016	4.8236	0 -0.016	0.0859	2.2389
SW32..W	2	1368	3578	2.0000	0 -0.00006	3.0000	0 -0.00100	7.7500	0 -0.016	6.3834	0 -0.016	0.1029	2.8379

MOTION COMPONENTS