

THE INFORMATION CONTAINED IN THIS DRAWING IS THE SOLE PROPERTY OF SPECIALTY MOTIONS INC. ANY REPRODUCTION IN PART OR WHOLE WITHOUT THE WRITTEN PERMISSION OF SPECIALTY MOTIONS INC. IS PROHIBITED.

REVISIONS			
REV.	DESCRIPTION	DATE	APPROVED
A	Initial Release	2-23-08	SC
B	MOD RAIL HOLE PATTERN. ADDED VIEWS ON SHEET 2	3-11-10	SC

- NOTES:
1. "xx" IN PART NUMBER DEFINES SYSTEM TRAVEL (IN INCHES).
 2. "yyyy" IN PART NUMBER DEFINES SCREW LEAD.
 3. FOR MATERIAL AND FINISH OF EACH ITEM, SEE INDIVIDUAL COMPONENT DRAWINGS.
 4. 21" SYSTEM TRAVEL SHOWN IN DRAWING FOR REFERENCE ONLY.
 5. SYSTEM TRAVEL TOLERANCE IS +.500 / -.000 OVER THAT SPECIFIED IN THE PART NUMBER.

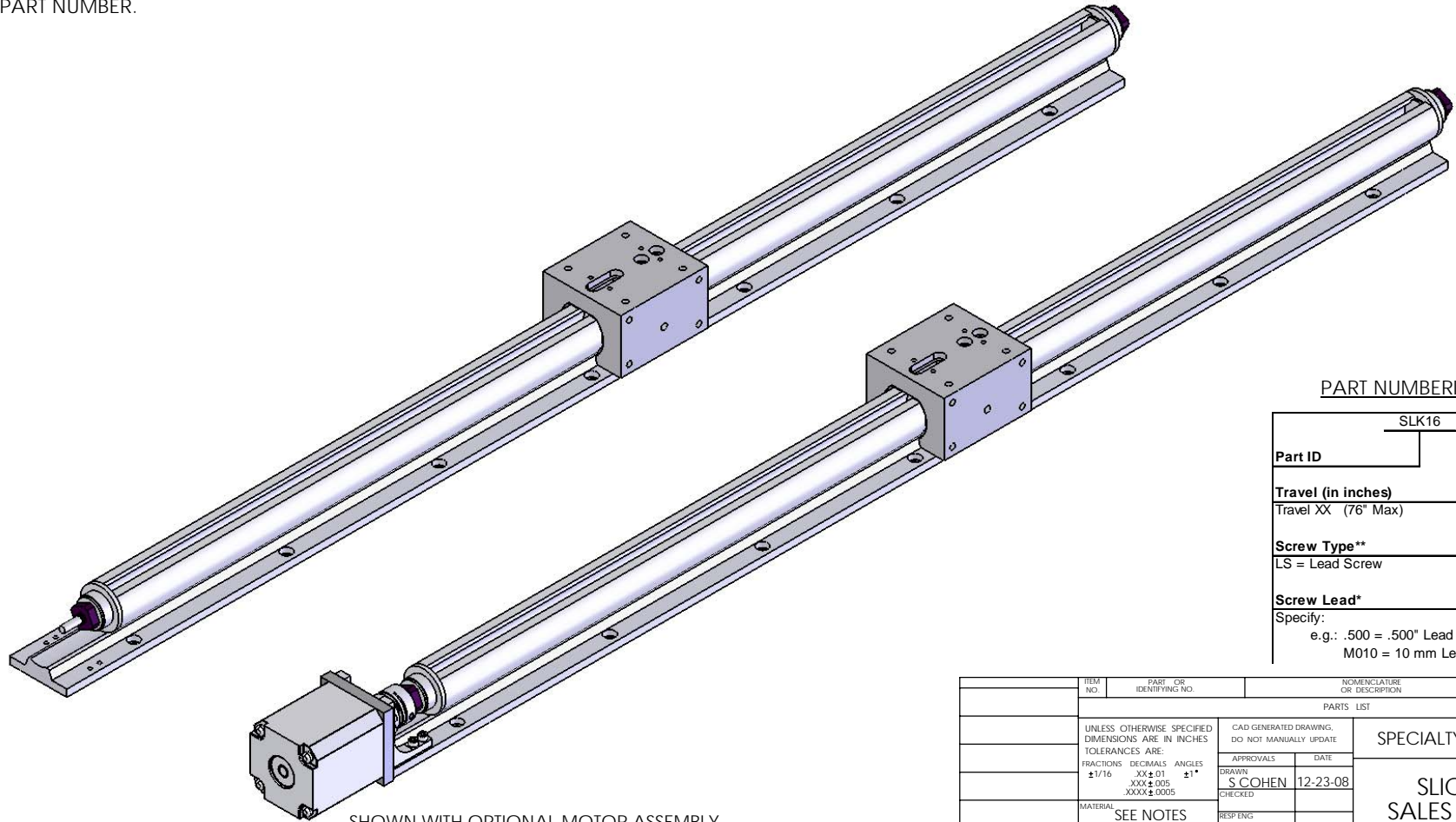

SHOWN WITH OPTIONAL MOTOR ASSEMBLY (SOLD SEPARATELY)

PART NUMBERING SCHEME:

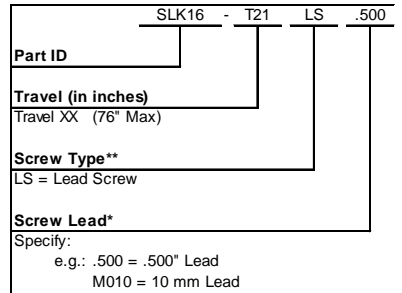

ITEM NO.	PART OR IDENTIFYING NO.	NOMENCLATURE OR DESCRIPTION	MATERIAL SPECIFICATION	QTY REQD.
PARTS LIST				
UNLESS OTHERWISE SPECIFIED DIMENSIONS ARE IN INCHES TOLERANCES ARE:		CAD GENERATED DRAWING. DO NOT MANUALLY UPDATE		
FRACTIONS DECIMALS ANGLES		APPROVALS	DATE	
±1/16	.XX ±.01	DRAWN	12-23-08	
	.XXX ±.005	CHECKED		
	.XXXX ±.0005	RESP ENG		
MATERIAL SEE NOTES		MFG ENG		
FINISH SEE NOTES		QUAL ENG		
USED ON APPLICATIONS		SCALE	DWG. NO. SLK16-TxxLSyyyy	REV. B
		CAD FILE	SHEET 1 OF 2	

SPECIALTY MOTIONS INC.
SLICK STICK
SALES DRAWING

THE INFORMATION CONTAINED IN THIS DRAWING IS THE SOLE PROPERTY OF SPECIALTY MOTIONS INC. ANY REPRODUCTION IN PART OR WHOLE WITHOUT THE WRITTEN PERMISSION OF SPECIALTY MOTIONS INC. IS PROHIBITED.

REVISIONS			
REV.	DESCRIPTION	DATE	APPROVED
A	Initial Release	12-23-08	SC
B	MOD RAIL HOLE PATTERN. ADDED VIEWS ON SHEET 2	3-11-10	SC

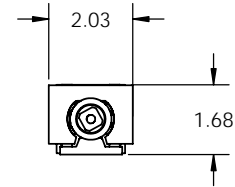
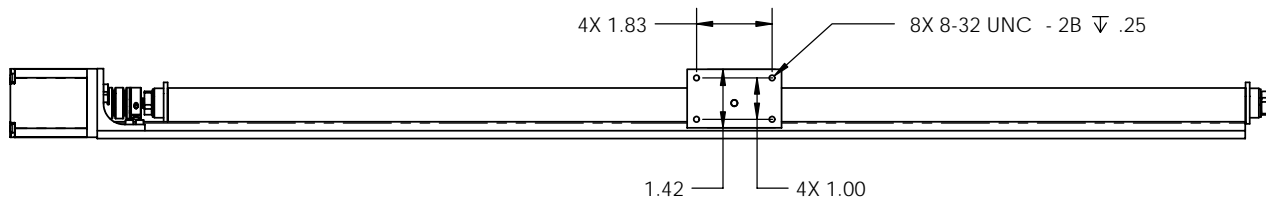
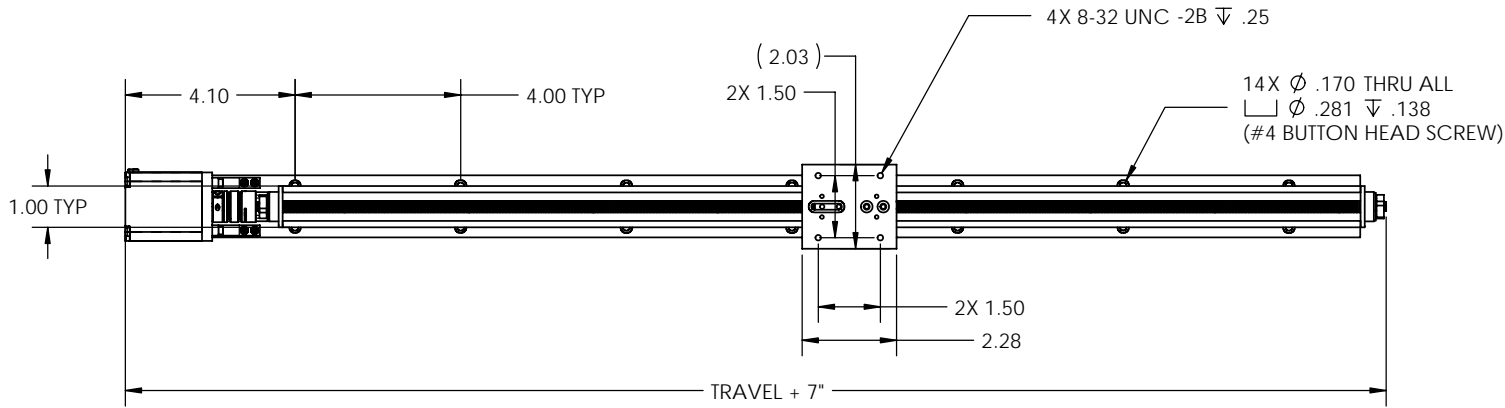

SHOWN WITH OPTIONAL MOTOR ASSEMBLY (SOLD SEPARATELY)
 SHOWN IN BASE CONFIGURATION

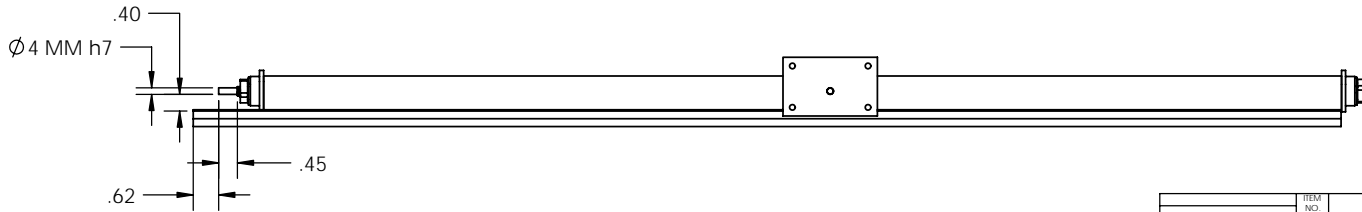

ITEM NO.	PART OR IDENTIFYING NO.	NOMENCLATURE OR DESCRIPTION	MATERIAL SPECIFICATION	QTY REQD.
PARTS LIST				
UNLESS OTHERWISE SPECIFIED DIMENSIONS ARE IN INCHES TOLERANCES ARE:		CAD GENERATED DRAWING. DO NOT MANUALLY UPDATE		
FRACTIONS $\pm 1/16$		DECIMALS $\pm .01$	ANGLES $\pm 1^\circ$	APPROVALS
MATERIAL		SEE NOTES	RESP ENG	DATE
FINISH		SEE NOTES	MFG ENG	12-23-08
USED ON APPLICATIONS		DO NOT SCALE DRAWING	QUAL ENG	
SPECIALTY MOTIONS INC.			SLICK STICK SALES DRAWING	REV. B
SCALE			DWG. NO. SLK16-TxxLSyyy	SHEET 2 OF 2